

ULD-50221

Lador 44 Pedestal Floodlight



Mounting Options



Threaded Knuckle

Construction

Aluminum

Less than 0.1% copper content – Marine Grade 6060 extruded & LM6 Aluminum High Pressure die casting provides excellent mechanical strength, clean detailed product lines and excellent heat dissipation.

Pre paint

8 step degrease and phosphate process that includes deoxidizing and etching as well as a zinc and nickel phosphate process before product painting.

Memory Retentive -Silicon Gasket

Provided with special injection molded "fit for purpose" long life high temperature memory retentive silicon gaskets. Maintains the gaskets exact profile and seal over years of use and compression.

Thermal management

LM6 Aluminum is used for its excellent mechanical strength and thermal dissipation properties in low and high ambient temperatures. The superior thermal heat sink design by Ligman used in conjunction with the driver, controls thermals below critical temperature range to ensure maximum luminous flux output, as well as providing long LED service life and ensuring less than 10% lumen depreciation at 50,000 hours.

Surge Suppression

Standard 10kv surge suppressor provided with all fixtures.

BUG Rating

B5 - U5 - G5

Finishing

All Ligman products go through an extensive finishing process that includes fettling to improve paint adherence.

Paint

UV Stabilized 4.9Mil thick powder coat paint and baked at 200 Deg C. This process ensures that Ligman products can withstand harsh environments. Rated for use in natatoriums.

Inspired by Nature Finishes

The Inspired by nature Finishing is a unique system of decorative powder coating. Our metal decoration process can easily transform the appearance of metal or aluminum product into a wood grain finish.

This patented technology enables the simulation of wood grain, and even marble or granite finish through the use of decorative powder coating.

The wood grain finish is so realistic that it's almost undistinguishable from real wood, even from a close visual inspection. The system of coating permeates the entire thickness of the coat and as a result, the coating cannot be removed by normal rubbing, chipping, or scratching.

The Coating Process

After pre-treatment the prepared parts are powder coated with a specially formulated polyurethane powder. This powder provides protection against wear, abrasion, impact and corrosion and acts as the relief base color for the finalized metal decoration.

The component is then wrapped with a sheet of non-porous film with the selected decoration pattern printed on it using special high temperature inks.

This printed film transfer is vacuum-sealed to the surface for a complete thermo print and then transferred into a customized oven. The oven transforms the ink into different forms within the paint layer before it becomes solid. Finally, the film is removed, and a vivid timber look on aluminum remains.

Wood grain coating can create beautiful wood-looking products of any sort. There are over 300 combinations of designs currently in use. Wood grains can be made with different colors, designs, etc.

Our powder coatings are certified for indoor and outdoor applications and are backed by a comprehensive warranty. These coatings rise to the highest conceivable standard of performance excellence and design innovation.

Added Benefits

- Resistance to salt-acid room, accelerated aging
- Boiling water, lime and condensed water resistant
- Anti-Graffiti, Anti-Slip, Anti-Microbial, Anti-Scratch
- Super durable (UV resistant)
- TGIC free (non-toxic)

Hardware

Provided Hardware is Marine grade 316 Stainless steel.

Anti Seize Screw Holes

Tapped holes are infused with a special anti seize compound designed to prevent seizure of threaded connections, due to electrolysis from heat, corrosive atmospheres and moisture.

Crystal Clear Low Iron Glass Lens

Provided with tempered, impact resistant crystal clear low iron glass ensuring no green glass tinge.

Optics & LED

Precise optic design provides exceptional light control and precise distribution of light. LED CRI > 80

Lumen - Maintenance Life

L80 /B10 at 50,000 hours (This means that at least 90% of the LED still achieve 80% of their original flux)

Square surface architectural floodlight range. Four sizes of square artistic precision with wide range of beam distributions.

A range of square outdoor IP66 floodlight projectors that meets both aesthetic and functional applications. This cubic floodlight range is available with 4 different sizes, starting with a small 2.4" square profile, and increases proportionately to 3", 4.5" and 5.5" square. This glare free luminaire is available in a selection of beam patterns.

This luminaire is engineered to meet harsh outdoor environments, as well as being able to be used as a decorative indoor product. The Lador is provided with a remote mount driver and has accessories that include; linear spread lens, honeycomb louvres and anti-glare visors.

This floodlight also has a unique aiming and locking system for precise mounting and beam aiming.

The Lador product family consists of; floodlights, wall sconces, ceiling mounted squares and cluster column event poles.

This luminaire is available with a natatorium rated coating.

Additional Options (Consult Factory For Pricing)



A51314 Linear Spread

A52021 Honeycomb Louvre

S20LGS Large Ground Spike 20"

A53031 Anti Glare Visor



A50181 24" Arm Pedestal



A50281 24" Arm Threaded Knuckle



A68391 STICK-DE3 [Nicolaudie]



A64491 TPC Touch Screen and Controller DMX [Pharos]



A64591 POE Connect [Pharos]



A64691 TPC Touch Screen and Controller DMX 2 [Pharos]



A64791 RDM DMX Splitter [Pharos]



A65191 TPC Touch Panel Station [Pharos]



A65391 EDN Ethernet Data Node [Pharos]



A66991 LPCX Lighting Playback Controller X [Pharos]



A64991 CLOUD [Pharos]



RGBW

22w LED 1133 Lumens
IP66 • Suitable For Wet Locations
IK08 • Impact Resistant (Vandal Resistant)
Weight 6.2 lbs

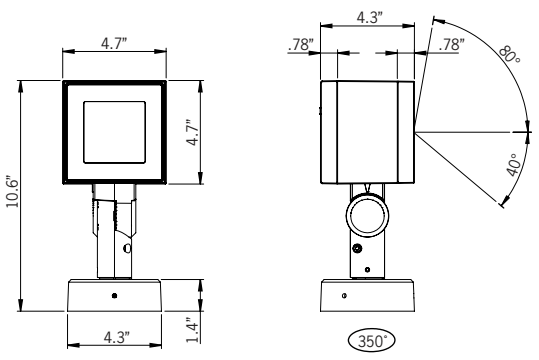

ULD-50221

Lador 44 Pedestal Floodlight



PROJECT		DATE	
----------------	--	-------------	--

QUANTITY		TYPE		NOTE	
-----------------	--	-------------	--	-------------	--

ORDERING EXAMPLE || ULD-50221-22w LED - N - RGBW30 - 02 - 120/277v

ULD-50221					
LAMP	BEAM	RGBW COLOR	FINISH COLOR	VOLTAGE	
22w LED 1133 lm	N - Narrow 8° M - Medium 17° W - Wide 26° VW - Very Wide 65° E - Elliptical 43° x 11°	RGBW30 - Warm White 3200K RGBW40 - Neutral White 4000K RGBW65 - Cool White 6850K	01 - BLACK RAL 9011 02 - DARK GREY RAL 7043 03 - WHITE RAL 9003 04 - METALLIC SILVER RAL 9006 05 - MATTE SILVER RAL 9006 06 - LIGMAN BRONZE 07 - CUSTOM RAL	120/277v Other - Specify	

ADDITIONAL OPTIONS		

- | | |
|---|--|
| <p>NAT - Natatorium Rated</p> <p>A51314 - Linear Spread Lens</p> <p>A52021 - Honeycomb Louvre</p> <p>S20LGS - Large Ground Spike 20"</p> <p>DIM - 0-10v Dimming</p>
<p>A68391 - STICK-DE3</p> <p>A64491 - TPC + DMX Controller</p> <p>A64591 - POE Connect</p> <p>A64691 - TPC + DMX 2</p> | <p>A53031 - Anti Glare Visor</p> <p>AMB - Turtle Friendly Amber LED</p> <p>A50181 - Surface Pedestal 24" Extended Arm</p> <p>A50281 - 1/2" Threaded 24" Extended Arm</p>
<p>A64791 - RDM DMX Splitter</p> <p>A65191 - TPC Touch Panel</p> <p>A65391 - EDN Ethernet Data Node</p> <p>A66991 - LPCX Lighting Playback</p> <p>A64991 - CLOUD</p> |
|---|--|

INSPIRED BY NATURE FINISHES

SW01 - OAK FINISH	
SW02 - WALNUT FINISH	
SW03 - PINE FINISH	
DF - DOUGLAS FIR FINISH	
CW - CHERRY WOOD FINISH	
NW - NATIONAL WALNUT FINISH	
SU01 - CONCRETE FINISH	
SU02 - SOFTSCAPE FINISH	
SU03 - STONE FINISH	
SU04 - CORTEN FINISH	

THERE IS AN ADDITIONAL COST FOR THESE FINISHES

More Custom Finishes Available Upon Request

Consult factory for pricing and lead times

Oak	Cherry	Beech	Carbon
Walnut	Chestnut	Bamboo	Galvanized
Pine	Mahogany	Birch	Steel





TPC Touchscreen & EXT Controller DMX & DALI 1 Universe

The TPC (Touch Panel Controller) is an elegant touch screen lighting controller with a customisable, 4.3" capacitive touch panel, 512 channels of eDMX output and vast interfacing potential, all over a single Power-over-Ethernet (PoE) network connection.

The EXT is an extension for the Pharos TPC and together they form a standalone, mainspowered lighting controller with versatile output and show control options. The EXT provides local DMX and DALI output for the TPC, as well as power and other hardware interfaces.



A64491



A64691

TPC Touchscreen & LPC Controller DMX 2 Universe

The LPC (Lighting Playback Controller) is an all-in-one control solution for themed entertainment and LED lighting installations. It features individually controllable and independently running timelines and scenes. Supported fixtures include LEDs in any configuration (RGB, RGBW, tunable white), moving heads, yokes or scanners and fountain jets. Output includes DMX512, Art-Net, DALI & RDM.

POE Connect

The POE (Power-over-Ethernet Switch) provides a simple power and networking solution for four Power-over-Ethernet devices with two separate Ethernet uplink ports. It is perfect for connecting power and data between Pharos Controllers and Pharos Remote Devices.



A64591



RDM DMX Splitters

The RDM (Remote Device Management) is a 4 port DMX512 Splitter compatible with the RDM standard to provide DMX output to luminaires and other devices. DMX splitters are an essential requirement for most control systems, allowing multiple separate cable runs from a single DMX output and ensuring electrical isolation.

A64791

TPS Touch Panel Station

The Pharos TPS (Touch Panel Station) is an elegant interface with a customizable, 4.3" capacitive touch screen, that works with any Pharos Controller



A65191



A64991

CLOUD

The CLOUD makes it easy to achieve remote control and management which is truly remote and totally secure.

Once connected, users can adjust hardware settings remotely, schedule tasks, control multiple projects, view system status, set remote user permissions, and more; through a standard internet connection without any additional hardware.

LPCX Lighting Playback Controller X

The Pharos LPC X (Lighting Playback Controller X) offers an extreme level of power and integration, making it an ideal solution for landmark lighting installations with significant channel counts. It integrates with the full range of Pharos products and offers an optional real-time video input



A66991



A65391

EDN Ethernet Data Node

The Pharos EDN (Ethernet Data Node) is a convenient and scalable solution, providing cost-effective Ethernet distributed DMX ports for large control projects. The EDN is an easily configurable networking node that is specifically designed to add physical DMX ports to Pharos Controllers and integrates natively with the full Pharos range.

Extremely compact, it packs up to 20 DMX512 output ports into a 1U 19" form factor. For higher port count installations, nodes can be daisy-chained to provide as many physical DMX ports as you need.

EDNs are discoverable through Pharos Designer software and associated to a Controller to be seamlessly configured as part of your patch. Ports can be flexibly assigned to any controller in your project providing an elegant data distribution solution over an Ethernet network with minimal setup required.

DMX/RDM Decoder - 24 VDC - Remote IP65 Box

- Control mode: RGBW / RGB / Custom / Dimming
- Compatible with DMX protocol (ANSI E1.11) and RDM function (ANSI E1.20)
- Output power: 33 W x 4 Channels (132 W max)
- Input voltage: 12-36 VDC
- Output voltage: 7.5-33 VDC



A67091



SLESA-U9

The Nicolaudie SLESA-U9 is a standalone USB based DMX256 lighting controller with 20 scenes and 1 zone. This simple and reliable control allows dynamic lighting scenes to be programmed quickly and easily through the ESA2 software for uninterrupted independent operation.



A60491



SLESA-U11

The Nicolaudie SLESA-U11 is a standalone engine (NSA) offering incredible power based DMX2048+ lighting controller with 99 scenes 5 zones, extended triggers and 16-bit channels management. Intuitive backlit keyboard with 10 presets and zone selection. Lighting scenes can be programmed quickly and easily through ESAPRO2 software via USB or Ethernet connection and mobile applications.

A66891

DMX Splitter & Amplifier in IP Box

Digital signal distributor is used with DMX512 digital lighting control signal for amplification and 2 channel distribution output. Each input/output interface adopts high voltage isolation technology, applied to DMX512 signal via remote transmission attenuation after the plastic amplification processing. Complete electrical isolation is used between the input interface and the distribution between output interface.



A63991



A67291

DINA-DR MICRO DMX Lighting Controller & Power Adapter

The DINA-DR MICRO is the perfect standalone lighting controller for simple DMX installations. It offers an affordable and programmable solution to replace automatic controllers.

Delivered with a DIN rail adapter, the DINA-DR MICRO can be mounted in an electrical cabinet and affords significant ease of installation.

Create your static or dynamic lighting scenes with ESA Pro 2 software and upload them to the DINA-DR MICRO through its USB connection. Specifications: 10 scenes, 1 zone, 60 channels.

STICK-DE3

The feature rich lighting controller has been designed to provide a control solution for the most demanding of projects, whilst maintaining an easy to use panel of touch sensitive buttons. The controller integrates a graphical color screen allowing scene photos to be displayed. Easily view the selected zone, scene name and design without the need to navigate through complex menus.

Change the speed, color and dimmer using the circular palette. The lighting levels, color and effects can be programmed from a PC, Mac, Android, iPad or iPhone using the included software



A68391

Lador Product Family



Lador 1

- ULD-50001-3w-222lm
- ULD-50002-4w RGBW-170lm



Lador 2

- ULD-50011-11w-904lm
- ULD-50012-10w RGBW-520lm



Lador 3

- ULD-50021-21w-1975lm
- ULD-50022-22w RGBW-1133lm



Lador 4

- ULD-50031-39w-3568lm
- ULD-50032-28w RGBW-1600lm



Lador 5/50

- ULD-30001-3w-222lm
- ULD-30041-4w RGBW-170lm



Lador 6/51

- ULD-30011-11w-904lm
- ULD-30051-10w RGBW-520lm



Lador 7/52

- ULD-30021-11w-904lm
- ULD-30061-22w RGBW-1133lm



Lador 8/53

- ULD-30031-39w-3568lm
- ULD-30071-28w RGBW-1600lm



Lador 9/32

- ULD-80001-3w-222lm
- ULD-80041-4w RGBW-170lm



Lador 10/33

- ULD-80011-11w-904lm
- ULD-80051-10w RGBW-520lm



Lador 11/34

- ULD-80021-21w-1975lm
- ULD-80061-22w RGBW-1133lm



Lador 12/35

- ULD-80031-39w-3568lm
- ULD-80071-28w RGBW-1600lm



Lador 13/14/15

- ULD-20011-4x21w-4x1975lm [13]
- ULD-20021-4x39w-4x3568lm [13]
- ULD-20012-4x21w-4x1975lm [19.6]
- ULD-20022-4x39w-4x3568lm [19.6]
- ULD-20011-4x21w-4x1975lm [26.2]
- ULD-20011-4x39w-4x3568lm [26.2]



Lador 1 TKM

- ULD-50041-3w-222lm



Lador 2 TKM

- ULD-50051-11w-904lm



Lador 3 TKM

- ULD-50061-21w-1975lm



Lador 4 TKM

- ULD-50071-39w-3568lm



Lador 20/42

- ULD-50081-3w-222lm
- ULD-50201-4w RGBW-170lm



Lador 21/43

- ULD-50091-11w-904lm
- ULD-50211-10w-520lm



Lador 22/44

- ULD-50101-21w-1975lm
- ULD-50221-22w RGBW-1133lm



Lador 23

- ULD-50111-39w-3568lm
- ULD-50231-28w RGBW-1600lm