

# ULW-10873

## Lightwave 2 Straight Bollard

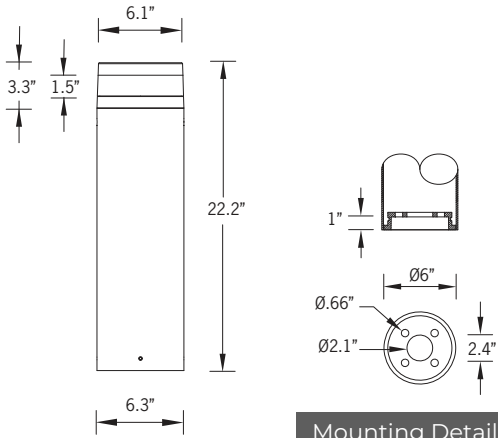

27w LED 475 Lumens  
IP65 · Suitable For Wet Locations  
IK08 · Impact Resistant (Vandal Resistant)  
Weight 12.1 lbs



Mounting Detail

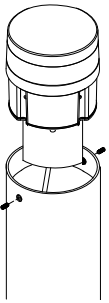

IP65 - Internal top access driver housing, prewired with SO cord and waterproof cable gland for easy installation.

### CITY OF FLAGSTAFF & TURTLE FRIENDLY COMPLIANT

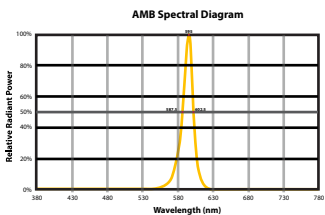

#### Narrow-Spectrum Amber LEDs

Peak wavelength between 585 & 595 nanometers and a full width of 50% power no greater than 15 nanometers.

### Construction

#### Aluminum

Less than 0.1% copper content - Marine Grade 6060 extruded & LM6 Aluminum High Pressure die casting provides excellent mechanical strength, clean detailed product lines and excellent heat dissipation.

#### Pre paint

8 step degrease and phosphate process that includes deoxidizing and etching as well as a zinc and nickel phosphate process before product painting.

#### Memory Retentive -Silicon Gasket

Provided with special injection molded "fit for purpose" long life high temperature memory retentive silicon gaskets. Maintains the gaskets exact profile and seal over years of use and compression.

#### Thermal management

LM6 Aluminum is used for its excellent mechanical strength and thermal dissipation properties in low and high ambient temperatures. The superior thermal heat sink design by Ligman used in conjunction with the driver, controls thermals below critical temperature range to ensure maximum luminous flux output, as well as providing long LED service life and ensuring less than 10% lumen depreciation at 50,000 hours.

#### Surge Suppression

Standard 10kv surge suppressor provided with all fixtures.

#### BUG Rating

B0 - U3 - G1

#### Finishing

All Ligman products go through an extensive finishing process that includes fettling to improve paint adherence.

#### Paint

UV Stabilized 4.9Mil thick powder coat paint and baked at 200 Deg C. This process ensures that Ligman products can withstand harsh environments. Rated for use in natatoriums.

#### MicroPRIM Finishes

MicroPRIM is Ligman's trade marked decorative powder coating technology that permanently infuses colors, patterns, or imagery directly into the surface of luminaires and poles while providing protections that standard powder coating does not offer.

MicroPRIM finishes include nature-inspired wood grains and stone aesthetics, material-inspired finishes such as brushed metal, concrete, and carbon fiber, Solid colors in Ligman standard colors, as well as any RAL or Pantone color, Decorative patterns, custom imagery and more.

#### Coating and Infusion Process

Metal components are pre-treated and powder coated with a proprietary polyurethane-based coating engineered for outdoor architectural use. Decorative patterns or imagery are then permanently infused into the cured powder coat through a heat-based process, creating a durable, integrated finish.

#### Performance and Validation

MicroPRIM finishes are suitable for indoor and outdoor applications and meet AAMA2605 architectural coating requirements. Performance is validated through laboratory and real-world testing to ASTM standards for UV exposure, adhesion, abrasion, impact, salt spray, chemical resistance, and graffiti resistance.

All MicroPRIM finishes are backed by Ligman's 10-year warranty.

#### Key Performance Attributes

- Anti-graffiti resistance
- UV and weather resistance
- Scratch and abrasion resistance
- Natatorium Rated for installation in corrosive environments

#### Hardware

Provided Hardware is Marine grade 316 Stainless steel.

#### Anti Seize Screw Holes

Tapped holes are infused with a special anti seize compound designed to prevent seizure of threaded connections, due to electrolysis from heat, corrosive atmospheres and moisture.

#### High Impact Acrylic Lens

Manufactured with Ultra High Impact, Naturally UV Stabilized Extruded Acrylic.

#### Optics & LED

Precise optic design provides exceptional light control and precise distribution of light. LED CRI > 80

#### Lumen - Maintenance Life

L80 /B10 at 50,000 hours (This means that at least 90% of the LED still achieve 80% of their original flux)

### Wide-distribution bollard fixture. Clean and effortlessly simple design bollard family with perfectly controlled wide-reaching light throw.

The Lightwave bollard features advanced reflector technology engineered to deliver high efficiency and superior visual comfort. Designed for precise downward illumination, Lightwave provides excellent uniformity and wide spacing ratios. The bollard is available in both straight and tapered profiles, offered in two standard heights, with custom heights available upon request.

A key feature of the Lightwave Bollard is its unique waterproof internal driver housing, positioned at the top of the pole to prevent water and dust from entering the electrical components. Each fixture is supplied fully wired, including a power cord and waterproof gland from the driver compartment to the bollard base, ensuring quick and trouble-free installation. Available color temperatures include 2700K, 3000K, 3500K, and 4000K.

Custom wattages can be provided to meet project needs, including Title 24 requirements. (Please specify total wattage per fixture.)

All Ligman luminaires can be manufactured using our specialized pre-treatment and coating process, allowing installation in natatoriums and environments with high concentrations of chlorine or salt—while still maintaining Ligman's 10-year warranty.

To request this natatorium-rated finish, please specify the **NAT** option.

### Additional Options (Consult Factory For Pricing)



10"  
10" Bollard Height  
*Not Available with  
Turtle Friendly Amber LED*



A91591  
Lockable In Use GFCI  
Receptacle Outlet Box



# ULW-10873

## Lightwave 2 Straight Bollard

PROJECT		DATE	
---------	--	------	--

QUANTITY		TYPE		NOTE	
----------	--	------	--	------	--

ORDERING EXAMPLE || ULW - 10873 - 27w - W30 - 02 - 120/277v - Options

<b>ULW-10873</b>				
LAMP	LED COLOR	FINISH COLOR	VOLTAGE	
27w LED 475 Lumens	W27 - 2700K W30 - 3000K W35 - 3500K W40 - 4000K AMB - <b>TURTLE FRIENDLY</b> Amber LED	01 - BLACK RAL 9011 02 - DARK GREY RAL 7043 03 - WHITE RAL 9003 04 - METALLIC SILVER RAL 9006 05 - MATTE SILVER RAL 9006 06 - LIGMAN BRONZE 07 - CUSTOM RAL	120/277v	

--	--	--

### ADDITIONAL OPTIONS

- NAT - Natatorium Rated
- HGT - Custom Bollard Height [Specify HGT=XX"]
- DIM - 0-10v Dimming

### More Custom Finishes Available Upon Request

Consult factory for pricing and lead times

#### MicroPRIM FINISHES

- SW01 - OAK FINISH
- SW02 - WALNUT FINISH
- SW03- PINE FINISH
- DF - DOUGLAS FIR FINISH
- CW - CHERRY WOOD FINISH
- NW - NATIONAL WALNUT FINISH
- SU01 - CONCRETE FINISH
- SU02 - SOFTSCAPE FINISH
- SU03 - STONE FINISH
- SU04 - CORTEN FINISH
- CSM - Custom Image/Pattern

#### MicroPRIM FINISHES

- MP - MAPLE FINISH
- MHG - MAHOGANY FINISH
- BH - BEECH FINISH
- CN - CHESTNUT FINISH
- WMBL - WHITE MARBLE FINISH
- MBL - MARBLE FINISH
- GRNT - GRANITE FINISH
- BGD - BRUSHED GOLD FINISH
- BBRZ - BRUSHED BRONZE FINISH
- CAMO - CAMOUFLAGE FINISH

- MP01 - MicroPRIM RAL 9011 Black (Glossy)
- MP02 - MicroPRIM RAL 7043 Dark Grey (Glossy)
- MP03 - MicroPRIM RAL 9003 White (Glossy)
- MP04 - MicroPRIM RAL 9006 Metallic Silver (Glossy)
- MP05 - MicroPRIM RAL 9006 Matte Silver (Matte/Textured)
- MP06 - MicroPRIM Ligman Bronze (Glossy)
- MP07 - MicroPRIM Custom Color (Glossy)



MicroPRIM Finish



# Lightwave Product Family



Lightwave 1

- ULW-10871-27w-475lm [22.2°]
- ULW-10872-27w-475lm [34.2°]



Lightwave 2

- ULW-10873-27w-475lm [22.2°]
- ULW-10874-27w-475lm [34.2°]



Lightwave 3

- ULW-30001-20w-285lm