

UDUH-10001

Solar Bench



RGB

5w LED 34 Lumens
IP65 • Suitable For Wet Locations
IK10 • Impact Resistant (Vandal Resistant)
Weight 315 lbs

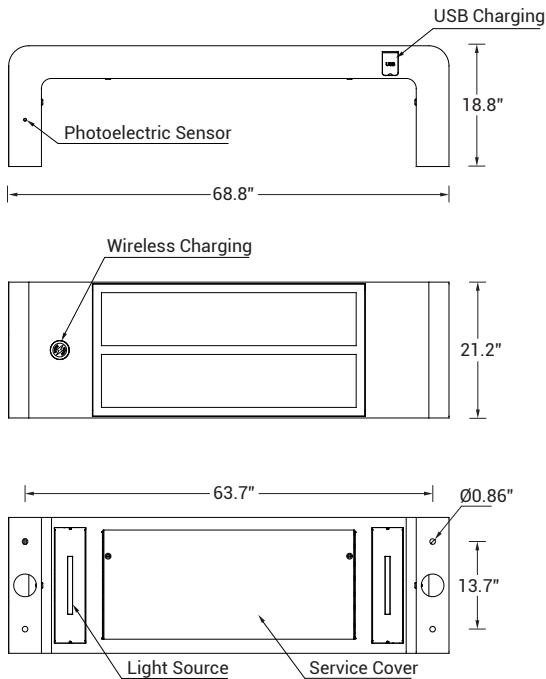

Construction

Formed, Heavy Gauge Galvanized Steel

Pre paint

8 step degrease and phosphate process that includes deoxidizing and etching as well as a zinc and nickel phosphate process before product painting.

Memory Retentive -Silicon Gasket

Provided with special injection molded "fit for purpose" long life high temperature memory retentive silicon gaskets. Maintains the gaskets exact profile and seal over years of use and compression.

Thermal management

LM6 Aluminum is used for its excellent mechanical strength and thermal dissipation properties in low and high ambient temperatures. The superior thermal heat sink design by Ligman used in conjunction with the driver, controls thermal below critical temperature range to ensure maximum luminous flux output, as well as providing long LED service life and ensuring less than 10% lumen depreciation at 50,000 hours.

Finishing

All Ligman products go through an extensive finishing process that includes fettling to improve paint adherence.

Paint

UV Stabilized 4.9Mil thick powder coat paint and baked at 200 Deg C. This process ensures that Ligman products can withstand harsh environments. Rated for use in natatoriums.

Hardware

Provided Hardware is Marine grade 316 Stainless steel.

Anti Seize Screw Holes

Tapped holes are infused with a special anti seize compound designed to prevent seizure of threaded connections, due to electrolysis from heat, corrosive atmospheres and moisture.

Crystal Clear Low Iron Glass Lens

Provided with tempered, impact resistant crystal clear low iron glass ensuring no green glass tinge.

Optics & LED

Precise optic design provides exceptional light control and precise distribution of light. LED CRI > 80

Operating Temp

-4°F to 104°F

Stylish signature seating bollard with numerous combination options for finishes and lighting. Combine your luminaire and seating needs into one piece of contemporary urban lighting furniture.

This modern bollard provides decorative glowing illumination, as well as seating at commercial building entrances, hotels, sports centers, as well as schools and universities.

This robust luminaire provides ambient light in the evenings as well as functional seating.

The luminaire has an incorporated LED band at the base of the bollard that provides a decorative glow as well as wireless and USB cell phone charging.

The Durham has an integrated, automatic color changing feature, that slowly rotates through the color spectrum, creating a unique visual glow below the bench.

This bollard is designed to support a 440lb static load.



UDUH-10001

Solar Bench



PROJECT	<input type="text"/>	DATE	<input type="text"/>
----------------	----------------------	-------------	----------------------

QUANTITY	<input type="text"/>	TYPE	<input type="text"/>	NOTE	<input type="text"/>
-----------------	----------------------	-------------	----------------------	-------------	----------------------

ORDERING EXAMPLE || UDUH-10001 - 5w - RGBW30 - 02 - 120/277V

UDUH-10001	<input type="text"/>	<input type="text"/>	<input type="text"/>	<input type="text"/>
-------------------	----------------------	----------------------	----------------------	----------------------

LAMP	RGBW COLOR	FINISH COLOR	VOLTAGE
------	------------	--------------	---------

5w LED
34 Lumens

RGBW30 - Warm White 3200K
 RGBW40 - Neutral White 4000K
 RGBW65 - Cool White 6850K

01 - BLACK RAL 9011
 02 - DARK GREY RAL 7043
 03 - WHITE RAL 9003
 04 - METALLIC SILVER RAL 9006
 05 - MATTE SILVER RAL 9006
 06 - LIGMAN BRONZE
 07 - CUSTOM RAL

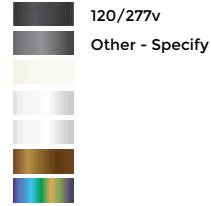

<input type="text"/>	<input type="text"/>
----------------------	----------------------

ADDITIONAL OPTIONS

NAT - Natatorium Rated

