

RGBW

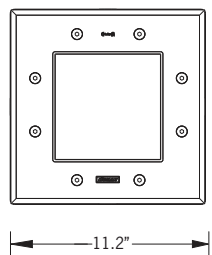

29w LED 1110 Lumens
 IP67 • Suitable For Wet Locations
 IK10 • Impact Resistant (Vandal Resistant)
 Weight 18 lbs

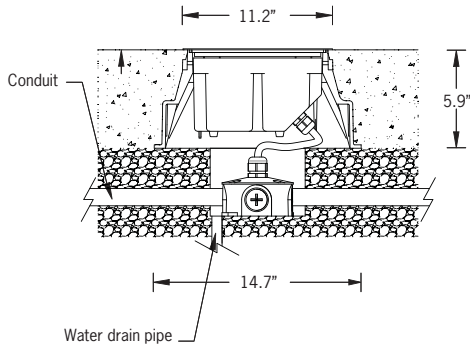

Adjustable LED Module

LED Module
TILT 10 Deg

ROTATE
360°



Construction

Frame Options

Extended Frame: Slightly raised & protruding over the edge of the recessing box, used to cover irregular finish around the recessing box e.g cut tiles.

Flush Frame: Installed flush with the floor surface, typically used with poured concrete or precision cut tiles.

Aluminum

Less than 0.1% copper content - Marine Grade 6060 extruded & LM6 Aluminum High Pressure die casting provides excellent mechanical strength, clean detailed product lines and excellent heat dissipation.

Pre paint

8 step degrease and phosphate process that includes deoxidizing and etching as well as a zinc and nickel phosphate process before product painting.

Memory Retentive -Silicon Gasket

Provided with special injection molded "fit for purpose" long life high temperature memory retentive silicon gaskets. Maintains the gaskets exact profile and seal over years of use and compression.

Thermal management

LM6 Aluminum is used for its excellent mechanical strength and thermal dissipation properties in low and high ambient temperatures. The superior thermal heat sink design by Ligman used in conjunction with the driver, controls thermals below critical temperature range to ensure maximum luminous flux output, as well as providing long LED service life and ensuring less than 10% lumen depreciation at 50,000 hours.

Surge Suppression

Standard 10kv surge suppressor provided with all fixtures.

BUG Rating

B3 - U5 - G5

Finishing

All Ligman products go through an extensive finishing process that includes fettling to improve paint adherence.

Paint

UV Stabilized 4.9Mil thick powder coat paint and baked at 200 Deg C. This process ensures that Ligman products can withstand harsh environments. Rated for use in natatoriums.

Hardware

Provided Hardware is Marine grade 316 Stainless steel.

Anti Seize Screw Holes

Tapped holes are infused with a special anti seize compound designed to prevent seizure of threaded connections, due to electrolysis from heat, corrosive atmospheres and moisture.

Crystal Clear Low Iron Glass Lens

Provided with tempered, impact resistant crystal clear low iron glass ensuring no green glass tinge.

Optics & LED

Precise optic design provides exceptional light control and precise distribution of light. LED CRI > 80

Lumen - Maintenance Life

L80 /B10 at 50,000 hours (This means that at least 90% of the LED still achieve 80% of their original flux)

Professional technical inground lighting solutions. Sophisticated and expansive; single, twin-lamp, white and RGBW DMX, with 7 beam types.

A top range of small shallow inground uplights with a round or square profile available with an extended or flush mounted frame. The fixture is manufactured with a marine grade 316 stainless steel front ring and is designed for use in shopping and pedestrian areas for illuminating building facades, columns, squares, parks, gardens, sculptures, flag poles and trees.

The adjustable high powered LED's in conjunction with high efficiency optics provides focused beam distributions to suit most design applications.

The tapered high density polyethylene inground recessing box is provided with securing lugs on each side to allow the installer to properly secure the box in place thereby stopping it from moving during the concrete pour procedure.

These securing lugs can also be used to secure the base to wood support beams and working in conjunction with the tapered recessing box will prevent the fixture from lifting when installed in dirt. The housing also has two shoulders to prevent fixture rotation when used in drive over applications.

The Kios is available with a non-slip ADA glass. This glass is infused with a specialized non-slip finish across the entire surface of the lens making this non-slip option the best in the industry.

To ensure efficient drainage, gravel must be used to a depth of 17" and a width of 12" beneath the housing, and should also be placed around the luminaire.

An animated video can be viewed on the Ligman website to show proper Kios installation procedure to assist contractors and ensure a problem-free installation.

Power is provided to the integral control gear through a specially developed anti-wicking PG13.5 watertight cable gland and 2ft of outdoor submersible #18/3 SOOW 600V power cable. Clear or frosted tempered 0.6" thick glass.

2.5 ton maximum load is transferred by the housing to the foundation. Vehicles with pneumatic tires can drive over the luminaire but the speed must not exceed 30mph. The distance between the floodlight and the illuminated surface should be at least 1.6'.

The Kios inground is available in 2700, 3000, 3500 and 4000 Kelvin, and is also available with colored dichroic filters, concentric ring louvre and honeycomb louvre.

This luminaire range is also available with specialized optics that provide Type II, III and IV distributions for floodlighting walls and monuments, see Kios 9, 10, 11 & 12.

The high power LED option is available in RGBW for the Kios 5, 6, 7 & 8.

Additional Options (Consult Factory For Pricing)

UKI-60598

KIOS 8 Ingrade Flush Frame

PROJECT		DATE	
----------------	--	-------------	--

QUANTITY		TYPE		NOTE	
-----------------	--	-------------	--	-------------	--

ORDERING EXAMPLE || UKI-60598-29w - N - RGBW30- 120/277v

UKI-60598				
	LAMP	BEAM	RGBW COLOR	VOLTAGE
	29w LED 1299 Lumens	N - Narrow 21° M - Medium 35° E - Elliptical 26°x48°	RGBW30 - Warm White 3200K RGBW40 - Neutral White 4000K RGBW65 - Cool White 6850K	120/277v Other - Specify

ADDITIONAL OPTIONS

- | | |
|---------------------------|------------------------------|
| F - Frosted Lens | A61612 - Anti Slip Lens |
| DIM - 0-10v Dimming | CRL - Concentric Ring Louvre |
| NAT - Natatorium Rated | AGL - Anti Glare Louvre |
| TORQ - Torque Screwdriver | LSL - Linear Spread Lens |

NOTE: A proper torque screwdriver set at 30 inch pounds must be used to tighten all screws securing the housing to the recessing box, as well as fastening the body and frame. Please specify TORQ in the additional options section to order a proper torque screwdriver for installation.

- | | |
|-------------------------------|---------------------------------|
| A65091 - STICK-KE2 | A64791 - RDM DMX Splitter |
| A68391 - STICK-DE3 | A65191 - TPC Touch Panel |
| A64491 - TPC + DMX Controller | A65391 - EDN Ethernet Data Node |
| A64591 - POE Connect | A66991 - LPCX Lighting Playback |
| A64691 - TPC + DMX 2 | A64991 - CLOUD |





TPC Touchscreen & EXT Controller DMX & DALI 1 Universe

The TPC (Touch Panel Controller) is an elegant touch screen lighting controller with a customisable, 4.3" capacitive touch panel, 512 channels of eDMX output and vast interfacing potential, all over a single Power-over-Ethernet (PoE) network connection.

The EXT is an extension for the Pharos TPC and together they form a standalone, mainspowered lighting controller with versatile output and show control options. The EXT provides local DMX and DALI output for the TPC, as well as power and other hardware interfaces.



A64491



A64691

TPC Touchscreen & LPC Controller DMX 2 Universe

The LPC (Lighting Playback Controller) is an all-in-one control solution for themed entertainment and LED lighting installations. It features individually controllable and independently running timelines and scenes. Supported fixtures include LEDs in any configuration (RGB, RGBW, tunable white), moving heads, yokes or scanners and fountain jets. Output includes DMX512, Art-Net, DALI & RDM.

POE Connect

The POE (Power-over-Ethernet Switch) provides a simple power and networking solution for four Power-over-Ethernet devices with two separate Ethernet uplink ports. It is perfect for connecting power and data between Pharos Controllers and Pharos Remote Devices.



A64591



RDM DMX Splitters

The RDM (Remote Device Management) is a 4 port DMX512 Splitter compatible with the RDM standard to provide DMX output to luminaires and other devices. DMX splitters are an essential requirement for most control systems, allowing multiple separate cable runs from a single DMX output and ensuring electrical isolation.

A64791

TPS Touch Panel Station

The Pharos TPS (Touch Panel Station) is an elegant interface with a customizable, 4.3" capacitive touch screen, that works with any Pharos Controller



A65191



A64991

CLOUD

The CLOUD makes it easy to achieve remote control and management which is truly remote and totally secure.

Once connected, users can adjust hardware settings remotely, schedule tasks, control multiple projects, view system status, set remote user permissions, and more; through a standard internet connection without any additional hardware.

LPCX Lighting Playback Controller X

The Pharos LPC X (Lighting Playback Controller X) offers an extreme level of power and integration, making it an ideal solution for landmark lighting installations with significant channel counts. It integrates with the full range of Pharos products and offers an optional real-time video input



A66991



A65391

EDN Ethernet Data Node

The Pharos EDN (Ethernet Data Node) is a convenient and scalable solution, providing cost-effective Ethernet distributed DMX ports for large control projects. The EDN is an easily configurable networking node that is specifically designed to add physical DMX ports to Pharos Controllers and integrates natively with the full Pharos range.

Extremely compact, it packs up to 20 DMX512 output ports into a 1U 19" form factor. For higher port count installations, nodes can be daisy-chained to provide as many physical DMX ports as you need.

EDNs are discoverable through Pharos Designer software and associated to a Controller to be seamlessly configured as part of your patch. Ports can be flexibly assigned to any controller in your project providing an elegant data distribution solution over an Ethernet network with minimal setup required.

DMX/RDM Decoder - 24 VDC - Remote IP65 Box

- Control mode: RGBW / RGB / Custom / Dimming
- Compatible with DMX protocol (ANSI E1.11) and RDM function (ANSI E1.20)
- Output power: 33 W x 4 Channels (132 W max)
- Input voltage: 12-36 VDC
- Output voltage: 7.5-33 VDC



A67091



SLESA-U9

The Nicolaudie SLESA-U9 is a standalone USB based DMX256 lighting controller with 20 scenes and 1 zone. This simple and reliable control allows dynamic lighting scenes to be programmed quickly and easily through the ESA2 software for uninterrupted independent operation.



A60491



SLESA-U11

The Nicolaudie SLESA-U11 is a standalone engine (NSA) offering incredible power based DMX2048+ lighting controller with 99 scenes 5 zones, extended triggers and 16-bit channels management. Intuitive backlit keyboard with 10 presets and zone selection. Lighting scenes can be programmed quickly and easily through ESAPRO2 software via USB or Ethernet connection and mobile applications.

A66891

DMX Splitter & Amplifier in IP Box

Digital signal distributor is used with DMX512 digital lighting control signal for amplification and 2 channel distribution output. Each input/output interface adopts high voltage isolation technology, applied to DMX512 signal via remote transmission attenuation after the plastic amplification processing. Complete electrical isolation is used between the input interface and the distribution between output interface.



A63991



DINA-DR MICRO DMX Lighting Controller & Power Adapter

The DINA-DR MICRO is the perfect standalone lighting controller for simple DMX installations. It offers an affordable and programmable solution to replace automatic controllers.

Delivered with a DIN rail adapter, the DINA-DR MICRO can be mounted in an electrical cabinet and affords significant ease of installation.

Create your static or dynamic lighting scenes with ESA Pro 2 software and upload them to the DINA-DR MICRO through its USB connection. Specifications: 10 scenes, 1 zone, 60 channels.

A67291

STICK-DE3

The feature rich lighting controller has been designed to provide a control solution for the most demanding of projects, whilst maintaining an easy to use panel of touch sensitive buttons. The controller integrates a graphical color screen allowing scene photos to be displayed. Easily view the selected zone, scene name and design without the need to navigate through complex menus.

Change the speed, color and dimmer using the circular palette. The lighting levels, color and effects can be programmed from a PC, Mac, Android, iPad or iPhone using the included software



A68391

Kios Product Family



Kios 1

- UKI-60445-6w-317lm
- UKI-60485-8w-658lm
- UKI-60486-7w-600lm
- UKI-60791-12w-1086lm



Kios 2

- UKI-60465-6w-317lm
- UKI-60505-8w-658lm
- UKI-60506-7w-600lm
- UKI-60751-12w-1086lm



Kios 3

- UKI-60455-6w-317lm
- UKI-60495-8w-658lm
- UKI-60496-7w-600lm
- UKI-60741-12w-1086lm



Kios 4

- UKI-60475-6w-317lm
- UKI-60515-8w-658lm
- UKI-60516-7w-600lm
- UKI-60761-12w-1086lm



Kios 5

- UKI-60568-29w RGBW-1299lm
- UKI-60771-30w-3160lm
- UKI-60775-33w-3320lm



Kios 6

- UKI-60588-29w RGBW-1299lm
- UKI-60791-30w-3160lm
- UKI-60795-33w-3320lm



Kios 7

- UKI-60578-29w RGBW-1299lm
- UKI-60781-30w-3160lm
- UKI-60785-33w-3320lm



Kios 8

- UKI-60598-29w RGBW-1299lm
- UKI-60801-30w-3160lm
- UKI-60805-33w-3320lm



Kios 9

- UKI-60647-25w-2739lm



Kios 10

- UKI-60667-25w-2739lm



Kios 11

- UKI-60657-25w-2739lm



Kios 12

- UKI-60677-25w-2739lm