

UHA-60209

Harrier 4 Ingrade

Construction

Aluminum

Less than 0.1% copper content - Marine Grade 6060 extruded & LM6 Aluminum High Pressure die casting provides excellent mechanical strength, clean detailed product lines and excellent heat dissipation.

Pre paint

8 step degrease and phosphate process that includes deoxidizing and etching as well as a zinc and nickel phosphate process before product painting.

Memory Retentive -Silicon Gasket

Provided with special injection molded "fit for purpose" long life high temperature memory retentive silicon gaskets. Maintains the gaskets exact profile and seal over years of use and compression.

Thermal management

LM6 Aluminum is used for its excellent mechanical strength and thermal dissipation properties in low and high ambient temperatures. The superior thermal heat sink design by Ligman used in conjunction with the driver, controls thermals below critical temperature range to ensure maximum luminous flux output, as well as providing long LED service life and ensuring less than 10% lumen depreciation at 50,000 hours.

Surge Suppression

Standard 10kv surge suppressor provided with all fixtures.

BUC Rating

B4 - U4 - G5

Finishing

All Ligman products go through an extensive finishing process that includes fettling to improve paint adherence.

Paint

UV Stabilized 4.9Mil thick powder coat paint and baked at 200 Deg C. This process ensures that Ligman products can withstand harsh environments. Rated for use in natatoriums.

Inspired by Nature Finishes

The Inspired by nature Finishing is a unique system of decorative powder coating. Our metal decoration process can easily transform the appearance of metal or aluminum product into a wood grain finish.

This patented technology enables the simulation of wood grain, and even marble or granite finish through the use of decorative powder coating.

The wood grain finish is so realistic that it's almost undistinguishable from real wood, even from a close visual inspection. The system of coating permeates the entire thickness of the coat and as a result, the coating cannot be removed by normal rubbing, chipping, or scratching.

The Coating Process

After pre-treatment the prepared parts are powder coated with a specially formulated polyurethane powder. This powder provides protection against wear, abrasion, impact and corrosion and acts as the relief base color for the finalized metal decoration.

The component is then wrapped with a sheet of non-porous film with the selected decoration pattern printed on it using special high temperature inks.

This printed film transfer is vacuum-sealed to the surface for a complete thermo print and then transferred into a customized oven. The oven transforms the ink into different forms within the paint layer before it becomes solid. Finally, the film is removed, and a vivid timber look on aluminum remains.

Wood grain coating can create beautiful wood-looking products of any sort. There are over 300 combinations of designs currently in use. Wood grains can be made with different colors, designs, etc.

Our powder coatings are certified for indoor and outdoor applications and are backed by a comprehensive warranty. These coatings rise to the highest conceivable standard of performance excellence and design innovation.

Added Benefits

- Resistance to salt-acid room, accelerated aging
- Boiling water, lime and condensed water resistant
- Anti-Graffiti, Anti-Slip, Anti-Microbial, Anti-Scratch
- Super durable (UV resistant)
- TGIC free (non-toxic)

Hardware

Provided Hardware is Marine grade 316 Stainless steel.

Anti Seize Screw Holes

Tapped holes are infused with a special anti seize compound designed to prevent seizure of threaded connections, due to electrolysis from heat, corrosive atmospheres and moisture.

Crystal Clear Low Iron Glass Lens

Provided with tempered, impact resistant crystal clear low iron glass ensuring no green glass tinge.

Optics & LED

Precise optic design provides exceptional light control and precise distribution of light.
LED CRI > 80

Lumen - Maintenance Life

L80 /B10 at 50,000 hours (This means that at least 90% of the LED still achieve 80% of their original flux)



15w LED 1468 Lumens
IP67 • Suitable For Wet Locations
IK10 • Impact Resistant (Vandal Resistant)
Weight 4.6 lbs (A) 5 lbs (S)

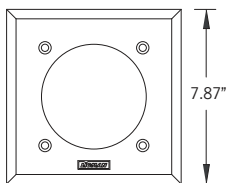
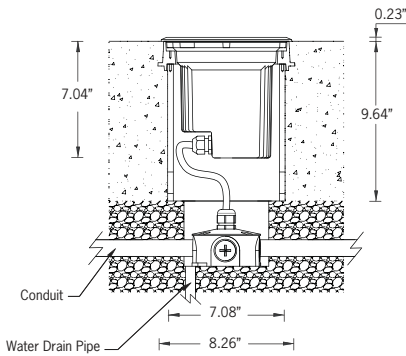

Complete, flexible, competitive accent and floodlight ingrounds. The lighting industry's leading quality low-cost inground fixture family.

A top range of inground uplights with a choice of round or square stainless steel or painted aluminum front rings. This 7.87" inground luminaire is provided with a low output LED board and integral driver, and is suitable as a marker light for illuminating shopping and pedestrian areas, parks, gardens and sculptures. This low glare luminaire is provided with a 0.4" thick tempered glass and is rated as a walkover luminaire. The glass has a special wrap around high temperature silicone gasket that provides additional ingress protection.

A non slip lens is available as an option. This non slip coating is a proprietary coating that is infused into the glass to provide excellent traction in wet conditions. To ensure efficient drainage, gravel must be used to a depth of 17" beneath the housing, and should also be placed around the luminaire. Low copper content die-cast aluminum housing with high corrosion resistance. The 0.24" thick front ring is available in grade 316 stainless steel or aluminum.

Stainless steel fasteners in grade 316. Power is provided through a single PG1/2" watertight cable gland.

UF-B 600v underground feeder cable is recommended to provide power to the luminaire. Standard recessing box in high density polyethylene.

NOTE: Includes remote mount driver & recessing box. Remote enclosure box can be specified in options.

Additional Options (Consult Factory For Pricing)



A80191
3" x 10" Remote Enclosure Box



A60212
Anti Slip Lens



UHA-60209

Harrier 4 Ingrade

PROJECT		DATE	
----------------	--	-------------	--

QUANTITY		TYPE		NOTE	
-----------------	--	-------------	--	-------------	--

ORDERING EXAMPLE || UHA-60209- 15w - A - N - W30- 120/277v

UHA-60209						
LAMP	FRAME	BEAM	LED COLOR	FINISH COLOR	VOLTAGE	
15w LED 1468 Lumens	A - Aluminum - CHOOSE FINISH COLOR S - Stainless Steel NO FINISH COLOR	N - Narrow 15° M - Medium 26° W - Wide 40°	W27 - 2700K W30 - 3000K W40 - 4000K	01 - BLACK RAL 9011 02 - DARK GREY RAL 7043 03 - WHITE RAL 9003 04 - METALLIC SILVER RAL 9006 05 - MATTE SILVER RAL 9006 06 - LIGMAN BRONZE 07 - CUSTOM RAL	120/277v Other - Specify	

--	--	--

ADDITIONAL OPTIONS

- F - Frosted Lens
- NAT - Natatorium Rated
- A80191 - 3"x10" Remote Box
- A60212 - Anti Slip Lens
- DIM - 0-10v Dimming

INSPIRED BY NATURE FINISHES

- SW01 - OAK FINISH
- SW02 - WALNUT FINISH
- SW03- PINE FINISH
- DF - DOUGLAS FIR FINISH
- CW - CHERRY WOOD FINISH
- NW - NATIONAL WALNUT FINISH
- SU01 - CONCRETE FINISH
- SU02 - SOFTSCAPE FINISH
- SU03 - STONE FINISH
- SU04 - CORTEN FINISH

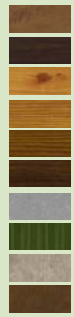

THERE IS AN ADDITIONAL COST FOR THESE FINISHES

More Custom Finishes Available Upon Request

Consult factory for pricing and lead times



Harrier Product Family



Harrier 1

- UHA-60036-6w-291lm
- UHA-60385-8w-733lm
- UHA-60386-8w-555lm



Harrier 2

- UHA-60196-6w-291lm
- UHA-60395-8w-733lm
- UHA-60396-8w-555lm



Harrier 3

- UHA-60049-15w-1468lm
- UHA-60050-29w-2899lm
- UHA-60295-6w-410lm
- UHA-60296-22w-2124lm



Harrier 4

- UHA-60209-15w-1468lm
- UHA-60215-29w-2899lm
- UHA-60305-6w-410lm
- UHA-60306-22w-2124lm