

UZA-50011

Zaab 2 Floodlight



* Pictured with A54231 Snoot

40w COB 3681 Lumens
IP66 • Suitable For Wet Locations
IK07 • Impact Resistant (Vandal Resistant)
Weight 8.1 lbs

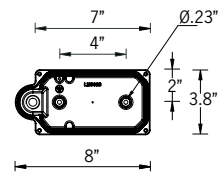
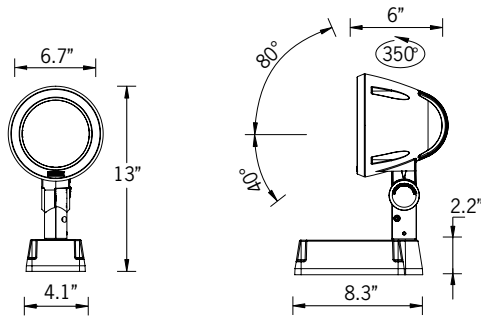

Mounting Detail

Construction

Aluminum
 Less than 0.1% copper content – Marine Grade 6060 extruded & LM6 Aluminum High Pressure die casting provides excellent mechanical strength, clean detailed product lines and excellent heat dissipation.

Pre paint
 8 step degrease and phosphate process that includes deoxidizing and etching as well as a zinc and nickel phosphate process before product painting.

Memory Retentive -Silicon Gasket
 Provided with special injection molded "fit for purpose" long life high temperature memory retentive silicon gaskets. Maintains the gaskets exact profile and seal over years of use and compression.

Thermal management
 LM6 Aluminum is used for its excellent mechanical strength and thermal dissipation properties in low and high ambient temperatures. The superior thermal heat sink design by Ligman used in conjunction with the driver, controls thermals below critical temperature range to ensure maximum luminous flux output, as well as providing long LED service life and ensuring less than 10% lumen depreciation at 50,000 hours.

Surge Suppression
 Standard 10kv surge suppressor provided with all fixtures.

BUG Rating
 B5 - U5 - G5

Finishing
 All Ligman products go through an extensive finishing process that includes fettling to improve paint adherence.

Paint
 UV Stabilized 4.9Mil thick powder coat paint and baked at 200 Deg C. This process ensures that Ligman products can withstand harsh environments. Rated for use in natatoriums.

Inspired by Nature Finishes
 The Inspired by nature Finishing is a unique system of decorative powder coating. Our metal decoration process can easily transform the appearance of metal or aluminum product into a wood grain finish.

This patented technology enables the simulation of wood grain, and even marble or granite finish through the use of decorative powder coating.

The wood grain finish is so realistic that it's almost undistinguishable from real wood, even from a close visual inspection. The system of coating permeates the entire thickness of the coat and as a result, the coating cannot be removed by normal rubbing, chipping, or scratching.

The Coating Process
 After pre-treatment the prepared parts are powder coated with a specially formulated polyurethane powder. This powder provides protection against wear, abrasion, impact and corrosion and acts as the relief base color for the finalized metal decoration.

The component is then wrapped with a sheet of non-porous film with the selected decoration pattern printed on it using special high temperature inks.

This printed film transfer is vacuum-sealed to the surface for a complete thermo print and then transferred into a customized oven. The oven transforms the ink into different forms within the paint layer before it becomes solid. Finally, the film is removed, and a vivid timber look on aluminum remains.

Wood grain coating can create beautiful wood-looking products of any sort. There are over 300 combinations of designs currently in use. Wood grains can be made with different colors, designs, etc.

Our powder coatings are certified for indoor and outdoor applications and are backed by a comprehensive warranty. These coatings rise to the highest conceivable standard of performance excellence and design innovation.

- Added Benefits**
- Resistance to salt-acid room, accelerated aging
 - Boiling water, lime and condensed water resistant
 - Anti-Graffiti, Anti-Slip, Anti-Microbial, Anti-Scratch
 - Super durable (UV resistant)
 - TGIC free (non-toxic)

Hardware
 Provided Hardware is Marine grade 316 Stainless steel.

Anti Seize Screw Holes
 Tapped holes are infused with a special anti seize compound designed to prevent seizure of threaded connections, due to electrolysis from heat, corrosive atmospheres and moisture.

Crystal Clear Low Iron Glass Lens
 Provided with tempered, impact resistant crystal clear low iron glass ensuring no green glass tinge.

Optics & LED
 Precise optic design provides exceptional light control and precise distribution of light.
 LED CRI > 80

Lumen - Maintenance Life
 L80 /B10 at 50,000 hours (This means that at least 90% of the LED still achieve 80% of their original flux)

Adjustable surface spotlight family. Conical, stylish spotlight range with a wealth of options and accessories.

The Zaab family of floodlights have a modern aesthetic design and are a perfect lighting solution for most small to medium size spotlight and floodlight requirements. The floodlights can be aimed and locked in place to highlight specific features or elements in the environment, as well as provide security when illuminating dark areas on campuses and parks. This small and medium range of high performance LED floodlight luminaires provides a robust design for demanding applications such as recreational areas, public spaces and architectural structures.

The luminaire has integrated heat sinks to facilitate LED cooling, as well as an integral driver. The Zaab is available in Narrow, Medium, Wide and Very Wide light distributions. Color temperature 2700K, 3000K, 3500K and 4000K.

Luminaire has optional accessories, such as visors, louvres, and linear spread lenses. For non standard fixture variations, as well as specific reflector requirements and dichroic filters, please contact the factory.

Additional Options (Consult Factory For Pricing)

A52631 Anti Glare Visor	A52731 Anti Glare Hood	A51721 Anti Glare Louvre	A51014 Linear Spread Lens
A54231 Snoot	Dichroic Color Filters	TKM 1/2 Threaded Knuckle Mount	

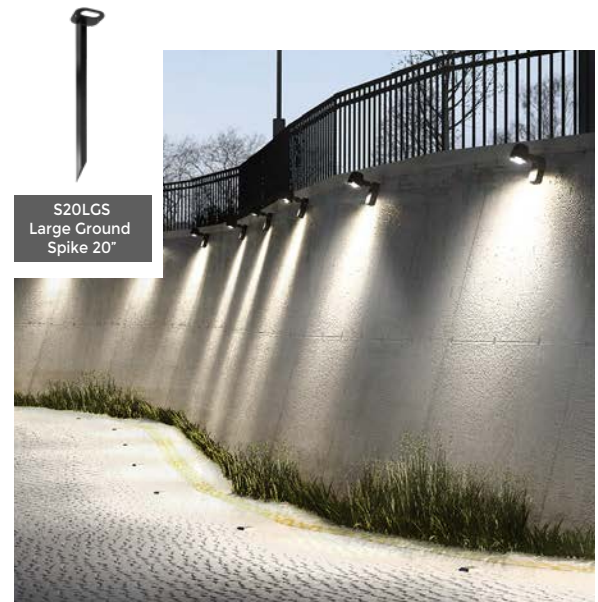

UZA-50011

Zaab 2 Floodlight

PROJECT		DATE	
----------------	--	-------------	--

QUANTITY		TYPE		NOTE	
-----------------	--	-------------	--	-------------	--

ORDERING EXAMPLE || UZA - 50011 - 40w COB - N - W30 - 02 - 120/277v

UZA-50011					
	LAMP	BEAM	LED COLOR	FINISH COLOR	VOLTAGE
	40w COB 3681 Lumens	N - Narrow 16° M - Medium 23° W - Wide 44° VW - Very Wide 69°	W27 - 2700K W30 - 3000K W35 - 3500K W40 - 4000K	01 - BLACK RAL 9011 02 - DARK GREY RAL 7043 03 - WHITE RAL 9003 04 - METALLIC SILVER RAL 9006 05 - MATTE SILVER RAL 9006 06 - LIGMAN BRONZE 07 - CUSTOM RAL	120/277v Other - Specify



--	--	--	--

ADDITIONAL OPTIONS

- F - Frosted Lens
- DIM - 0-10v Dimming
- NAT - Natatorium Rated
- A52631 - Anti Glare Visor
- A52731 - Anti Glare Hood

- A51721 - Anti Glare Louvre
- A51014 - Linear Spread Lens
- A54231 - Snoot
- TKM - 1/2" Threaded Knuckle Mount
- S20LGS - Large Ground Spike 20"

- DICHROIC COLOR FILTERS**
- A51016 - Red Color Filter
 - A51017 - Blue Color Filter
 - A51018 - Amber Color Filter
 - A51019 - Green Color Filter

INSPIRED BY NATURE FINISHES

SW01 - OAK FINISH	
SW02 - WALNUT FINISH	
SW03 - PINE FINISH	
DF - DOUGLAS FIR FINISH	
CW - CHERRY WOOD FINISH	
NW - NATIONAL WALNUT FINISH	
SU01 - CONCRETE FINISH	
SU02 - SOFTSCAPE FINISH	
SU03 - STONE FINISH	
SU04 - CORTEN FINISH	

THERE IS AN ADDITIONAL COST FOR THESE FINISHES

More Custom Finishes Available Upon Request

Consult factory for pricing and lead times

Oak	Cherry	Beech	Carbon
Walnut	Chestnut	Bamboo	Galvanized
Pine	Mahogany	Birch	Steel



Zaab Product Family



Zaab 1

• UZA-50001-21w-1739lm



Zaab 2

• UZA-50011-40w-4019lm



Zaab 3

• UZA-20001-3x40w-3x4091lm
• UZA-20011-6x40w-6x4091lm