

USIN-10001

Sindhu 1 Bollard



Construction

Aluminum

Less than 0.1% copper content – Marine Grade 6060 extruded & LM6 Aluminum High Pressure die casting provides excellent mechanical strength, clean detailed product lines and excellent heat dissipation.

Pre paint

8 step degrease and phosphate process that includes deoxidizing and etching as well as a zinc and nickel phosphate process before product painting.

Memory Retentive -Silicon Gasket

Provided with special injection molded "fit for purpose" long life high temperature memory retentive silicon gaskets. Maintains the gaskets exact profile and seal over years of use and compression.

Thermal management

LM6 Aluminum is used for its excellent mechanical strength and thermal dissipation properties in low and high ambient temperatures. The superior thermal heat sink design by Ligman used in conjunction with the driver, controls thermals below critical temperature range to ensure maximum luminous flux output, as well as providing long LED service life and ensuring less than 10% lumen depreciation at 50,000 hours.

Surge Suppression

Standard 10kv surge suppressor provided with all fixtures.

BUG Rating

90° & 90° x 90° | B0 - U1 - G0
270° & 360° | B1 - U2 - G1

Finishing

All Ligman products go through an extensive finishing process that includes fettling to improve paint adherence.

Paint

UV Stabilized 4.9mil thick powder coat paint and baked at 200° C. This process ensures that Ligman products can withstand harsh environments. Rated for use in natatoriums.

Inspired by Nature Finishes

The Inspired by nature Finishing is a unique system of decorative powder coating. Our metal decoration process can easily transform the appearance of metal or aluminum product into a wood grain finish.

This patented technology enables the simulation of wood grain, and even marble or granite finish through the use of decorative powder coating.

The wood grain finish is so realistic that it's almost undistinguishable from real wood, even from a close visual inspection. The system of coating permeates the entire thickness of the coat and as a result, the coating cannot be removed by normal rubbing, chipping, or scratching.

The Coating Process

After pre-treatment the prepared parts are powder coated with a specially formulated polyurethane powder. This powder provides protection against wear, abrasion, impact and corrosion and acts as the relief base color for the finalized metal decoration.

The component is then wrapped with a sheet of non-porous film with the selected decoration pattern printed on it using special high temperature inks.

This printed film transfer is vacuum-sealed to the surface for a complete thermo print and then transferred into a customized oven. The oven transforms the ink into different forms within the paint layer before it becomes solid. Finally, the film is removed, and a vivid timber look on aluminum remains.

Wood grain coating can create beautiful wood-looking products of any sort. There are over 300 combinations of designs currently in use. Wood grains can be made with different colors, designs, etc.

Our powder coatings are certified for indoor and outdoor applications and are backed by a comprehensive warranty. These coatings rise to the highest conceivable standard of performance excellence and design innovation.

Added Benefits

- Resistance to salt-acid room, accelerated aging
- Boiling water, lime and condensed water resistant
- Anti-Graffiti, Anti-Slip, Anti-Microbial, Anti-Scratch
- Super durable (UV resistant)
- TGIC free (non-toxic)

Hardware

Provided Hardware is Marine grade 316 Stainless steel.

Anti Seize Screw Holes

Tapped holes are infused with a special anti seize compound designed to prevent seizure of threaded connections, due to electrolysis from heat, corrosive atmospheres and moisture.

Crystal Clear Low Iron Glass Lens

Provided with tempered, impact resistant crystal clear low iron glass ensuring no green glass tinge.

Optics & LED

Precise optic design provides exceptional light control and precise distribution of light.

LED CRI > 80

Lumen - Maintenance Life

L80 /B10 at 50,000 hours (This means that at least 90% of the LED still achieve 80% of their original flux)

Modern , discrete way finding bollard. Featuring 360°, 270°, 180°, 90° and 90° x 90° beam distribution for uninterrupted pedestrian lighting.

A range of flat topped, disc head bollards providing downward light distributions. Ideally suited to illuminate walkways, as well as providing decorative light accents in parks and public spaces using high efficiency LEDs.

The Sindhu is suitable for indoor and outdoor applications and provides a clean, visually appealing solution for small, unobtrusive bollard installations.

This product is provided with integral driver and special gasketing to ensure no water enters the luminaire. This product is provided with anchor bolts and laser cut steel bolt template to ensure accurate installation.

All Ligman fixtures can be manufactured using a special pre-treatment and coating process that ensures the fixture can be installed in natatoriums as well as environments with high concentrations of chlorine or salt and still maintain the 5 year warranty. For this natatorium rated process please specify NAT in options.

This luminaire is offered in our Inspired by Nature finishes. Pricing for these finishes differs from our standard solid color paint options. Contact factory for pricing on these products.

Ligman can also offer Vandal Resistant Support. This insert can be used to provide extra rigidity in high pedestrian areas where the bollard is prone to being bumped into or potentially pushed over.

- 11w LED - 937 Lumens | 90° Distribution
- 19w LED - 1695 Lumens | 180° Distribution
- 19w90 LED - 1680 Lumens | 90° x 90° Distribution
- 23w LED - 2232 Lumens | 270° Distribution
- 34w LED - 3321 Lumens | 360° Distribution

- IP65 • Suitable For Wet Locations
- IK07 • Impact Resistant (Vandal Resistant)
- Weight 14 lbs

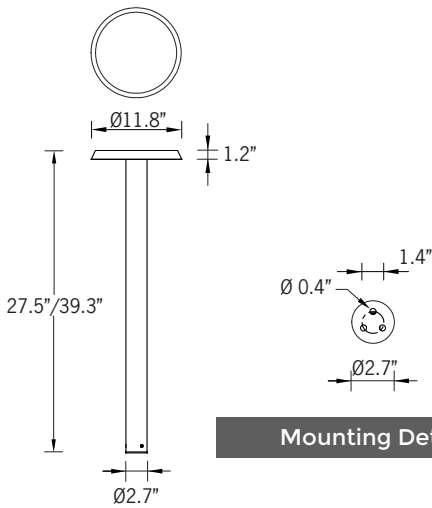

Mounting Detail



Additional Options (Consult Factory For Pricing)

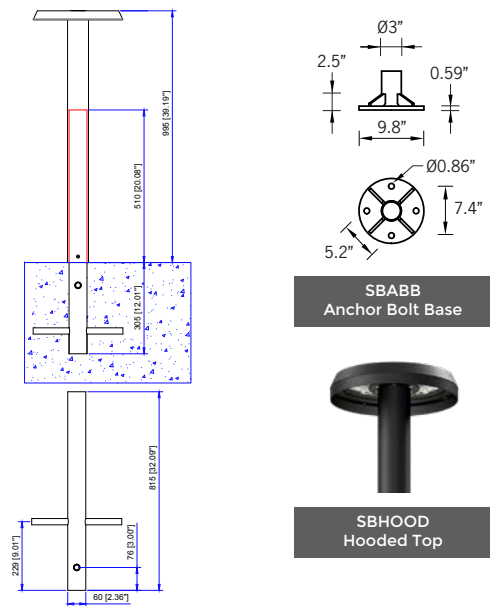

SBVRS
Vandal Resistant
Support

USIN-10001

Sindhu 1 Bollard

PROJECT		DATE	
----------------	--	-------------	--

QUANTITY		TYPE		NOTE	
-----------------	--	-------------	--	-------------	--

ORDERING EXAMPLE || USIN - 10001 - 19w90 - W30 - 02 - 27.5 - 120/277v - Options

USIN-10001					
	LAMP + BEAM	LED COLOR	FINISH COLOR	HEIGHT	VOLTAGE
	<ul style="list-style-type: none"> 11w - 11w LED 937 Lumens 90° Beam 19w - 19w LED 1695 Lumens 180° Beam 19w90 - 19w LED 1680 Lumens 90° x 90° Beam 23w - 23w LED 2232 Lumens 270° Beam 34w - 34w LED 3321 Lumens 360° Beam 	<ul style="list-style-type: none"> W27 - 2700K W30 - 3000K W35 - 3500K W40 - 4000K 	<ul style="list-style-type: none"> 01 - BLACK RAL 9011 02 - DARK GREY RAL 7043 03 - WHITE RAL 9003 04 - METALLIC SILVER RAL 9006 05 - MATTE SILVER RAL 9006 06 - LIGMAN BRONZE 07 - CUSTOM RAL 	<ul style="list-style-type: none"> 27.5" 39.3" SPECIFY OTHER 	<ul style="list-style-type: none"> 120/277v Other - Specify

--	--	--

ADDITIONAL OPTIONS

- NAT - Natatorium Rated
- SBVRS - Vandal Resistant Support
- HGT - Custom Bollard Height
- SBABB - Anchor Bolt Base
- AMB - Turtle Friendly Amber LED
- SBHOOD - Hooded Top

INSPIRED BY NATURE FINISHES	
SW01 - OAK FINISH	
SW02 - WALNUT FINISH	
SW03 - PINE FINISH	
DF - DOUGLAS FIR FINISH	
CW - CHERRY WOOD FINISH	
NW - NATIONAL WALNUT FINISH	
SU01 - CONCRETE FINISH	
SU02 - SOFTSCAPE FINISH	
SU03 - STONE FINISH	
SU04 - CORTEN FINISH	

THERE IS AN ADDITIONAL COST FOR THESE FINISHES

More Custom Finishes Available Upon Request

Consult factory for pricing and lead times

Oak	Cherry
Walnut	Chestnut
Pine	Mahogany
Beech	Carbon
Bamboo	Galvanized
Birch	Steel



Example: Inspired by Nature Finish

Sindhu Product Family



Sindhu 1

- USIN-10001-11w-937lm
- USIN-10001-19w-1695lm
- USIN-10001-19w90-1680lm
- USIN-10001-23w-2232lm
- USIN-10001-34w-3321lm



Sindhu 2

- USIN-20001-11w-937lm
- USIN-20001-19w-1680lm
- USIN-20001-19w90w-1695lm
- USIN-20001-23w-2232lm
- USIN-20001-34w-3321lm